

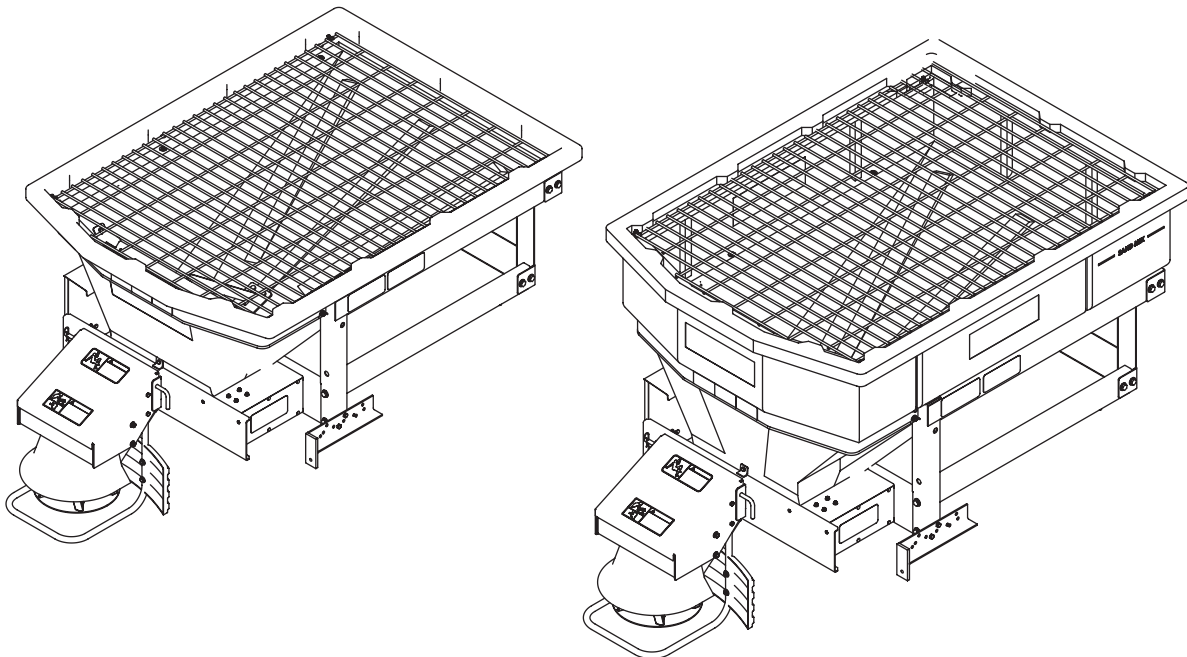

V-Pro™ Hopper Spreader

32300 & 32600

Parts List



This Parts List is for SnowEx® model 32300 and 32600 hopper spreaders with serial numbers beginning with 190901 and higher.

32300 & 32600 V-PRO™ HOPPER SPREADERS

FRAME AND HOPPER – MODEL 32300

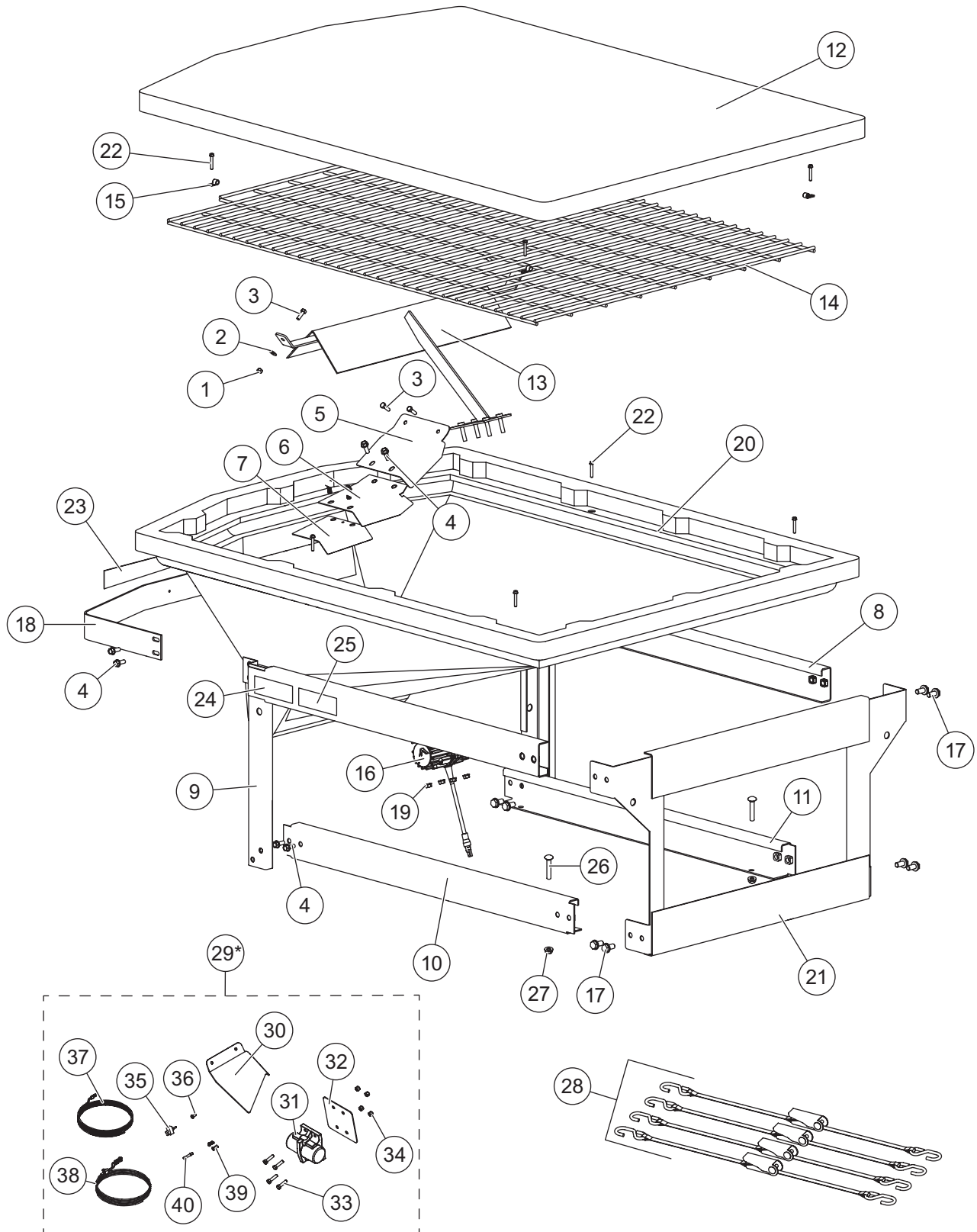

32300 & 32600 V-PRO™ HOPPER SPREADERS

Frame and Hopper – Model 32300 (0.5 yd ³ spreader)							
Item	Part	Qty	Description	Item	Part	Qty	Description
1	91332	4	5/16-18 Hex Locknut GB	17	51074	8	1/2-13 x 1 Serrated Flange Hex Cap Screw G5
2	90313	4	5/16 Flat Washer	18	51075	1	Hopper Apron
3	68494	4	5/16-18 x 1 Hex Cap Screw	19	51092	4	3/8-16 Serrated Flange Nut
4	51049	12	3/8-16 x 1 Serrated Flange Hex Cap Screw	20	D6585	1	Hopper, 0.5 yd ³ , SnowEx®
5	51052	1	Main Baffle	21	D6738	1	Front Frame
6	51053	1	Secondary Baffle	22	51103	8	1/4 x 1-1/2 Driller Screw w/Washer
7	51054	1	Third Baffle	23	51104	1	Conspicuity Tape
8	D6490	1	Frame, DS	24	93115	1	Label – Danger, Do Not Remove Spreader
9	D6491	1	Frame, PS	25	11100	1	Label – Warning, Rear Camera
10	D6496	1	Lower Rail, PS	ns	93107	1	Label – Warning, GVWR
11	D6497	1	Lower Rail, DS	ns	93106	1	Label – Warning, Read Manual
12	D6499	1	Poly Tarp Kit (includes straps)	26		4	1/2-13 x 3 Carriage Bolt
13	D6504	1	Inverted V – V-Pro™ Hopper	27		4	1/2-13 Serrated Flange Nut
14	D6506	1	Top Screen – V-Pro Hopper	28	51063	1	Ratchet Strap (pkg of 4)
15	D6509	4	1/4 Cushioned Clamp SS	29*	51106	1	Optimum Flow Kit
16	51068	1	DC-200 Vibrator				
Item 29*				51106 Optimum Flow Kit			
30	88295	1	Opti-Flow Baffle	36	88291	1	Rubber Switch Boot
31	88283	1	DC-80 Vibrator	37	88289	1	Spreader/Vehicle Harness, 20'
32	88284	1	Vibrator Backing Plate	38	88290	1	Battery Harness, 10'
33	90043	4	3/8-16 x 2 Hex Cap Screw G5	39	88294	2	Spade Connector
34	91333	4	3/8-16 Hex Locknut GB	40	88287	1	Butt Connector
35	88285	1	ON/OFF Switch	ns	88288	1	Dielectric Grease
G = Grade		DS = Driver's Side		PS = Passenger's Side		SS = Stainless Steel	

* = Accessory Only

32300 & 32600 V-PRO™ HOPPER SPREADERS

FRAME AND HOPPER – MODEL 32600

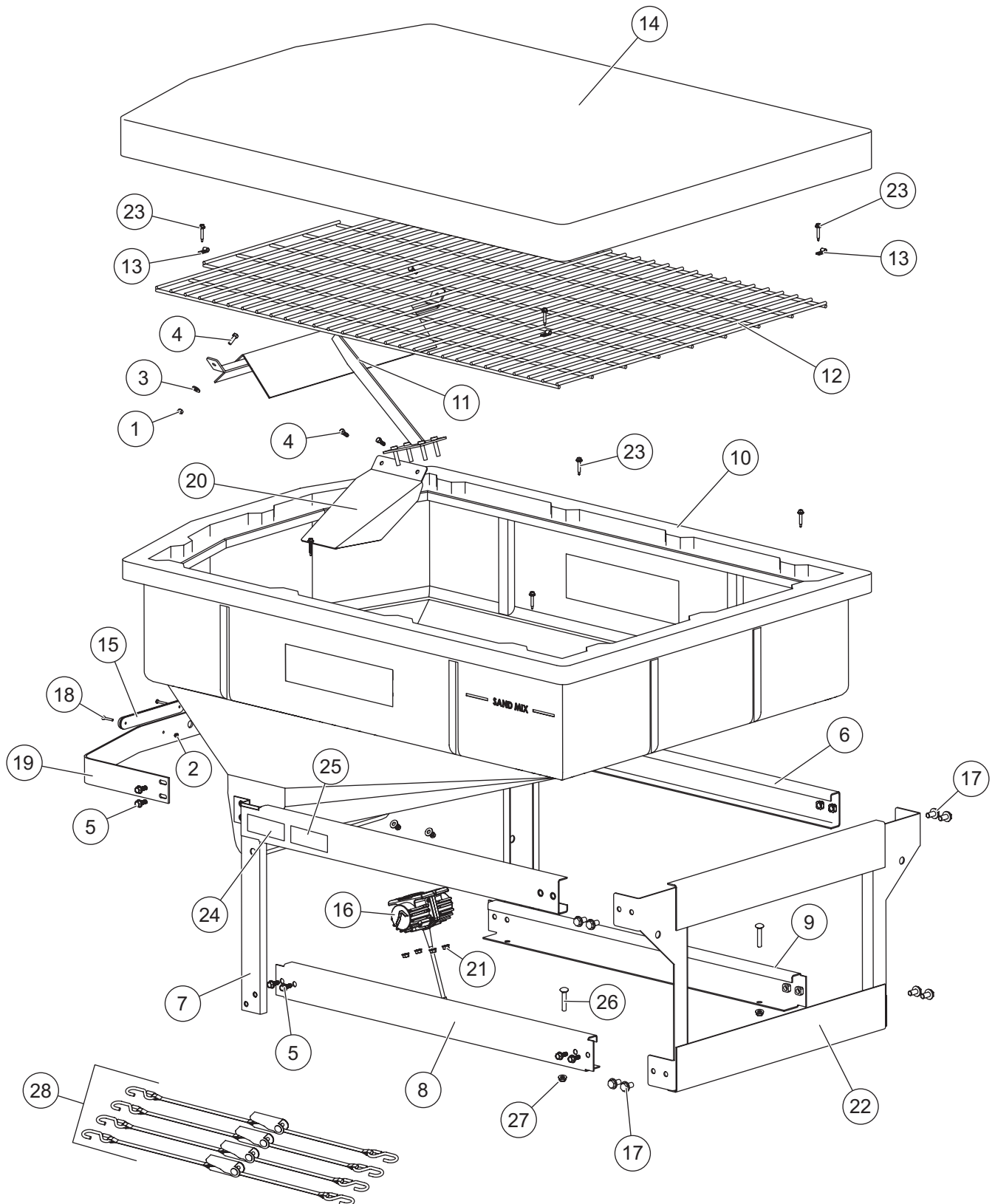

32300 & 32600 V-PRO™ HOPPER SPREADERS

Frame and Hopper – Model 32600 (1 yd ³ Spreader)							
Item	Part	Qty	Description	Item	Part	Qty	Description
1	91332	4	5/16-18 Hex Locknut GB	17	51074	8	1/2-13 x 1 Serrated Flange Hex Cap Screw G5
2	D6158	2	#10-32 Locknut	18	D6529	2	#10-32 x 1-1/4 Phillips Pan-Head Screw SS
3	90313	4	5/16 Flat Washer	19	51075	1	Hopper Apron
4	68494	4	5/16-18 x 1 Hex Cap Screw	20	D6577	1	Material Baffle
5	51049	12	3/8-16 x 1 Serrated Flange Hex Cap Screw	21	51092	4	3/8-16 Serrated Flange Nut
6	D6490	1	Frame, DS	22	D6738	1	Front Frame
7	D6491	1	Frame, PS	23	51103	8	1/4 x 1-1/2 Driller Screw w/Washer
8	D6496	1	Lower Rail, PS	24	93115	1	Label – Danger, Do Not Remove
9	D6497	1	Lower Rail, DS	25	11100	1	Label – Warning, Rear Camera
10	D6500	1	Hopper, 1 yd ³ , SnowEx®	ns	93107	1	Label – Warning, GVWR
11	D6504	1	Inverted V – V-Pro™ Hopper	ns	93106	1	Label – Warning, Read Manual
12	D6506	1	Top Screen – V-Pro Hopper	26		4	1/2-13 x 3 Carriage Bolt
13	D6509	4	1/4 Cushioned Clamp SS	27		4	1/2-13 Serrated Flange Nut
14	D6510	1	Poly Tarp Kit (includes straps)	28	51063	1	Ratchet Strap (pkg of 4)
15	D6514	1	CHMSL Brake Light	29*	51106	1	Optimum Flow Kit
16	51068	1	DC-200 Vibrator				
Item 29*				51106 Optimum Flow Kit			
30	88295	1	Opti-Flow Baffle	36	88291	1	Rubber Switch Boot
31	88283	1	DC-80 Vibrator	37	88289	1	Spreader/Vehicle Harness, 20'
32	88284	1	Vibrator Backing Plate	38	88290	1	Battery Harness, 10'
33	90043	4	3/8-16 x 2 Hex Cap Screw G5	39	88294	2	Spade Connector
34	91333	4	3/8-16 Hex Locknut GB	40	88287	1	Butt Connector
35	88285	1	ON/OFF Switch	ns	88288	1	Dielectric Grease
G = Grade		DS = Driver's Side		PS = Passenger's Side		SS = Stainless Steel ns = not shown	

* = Accessory Only

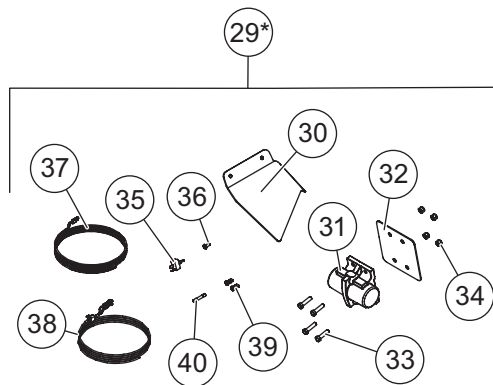

32300 & 32600 V-PRO™ HOPPER SPREADERS

AUGER ASSEMBLY

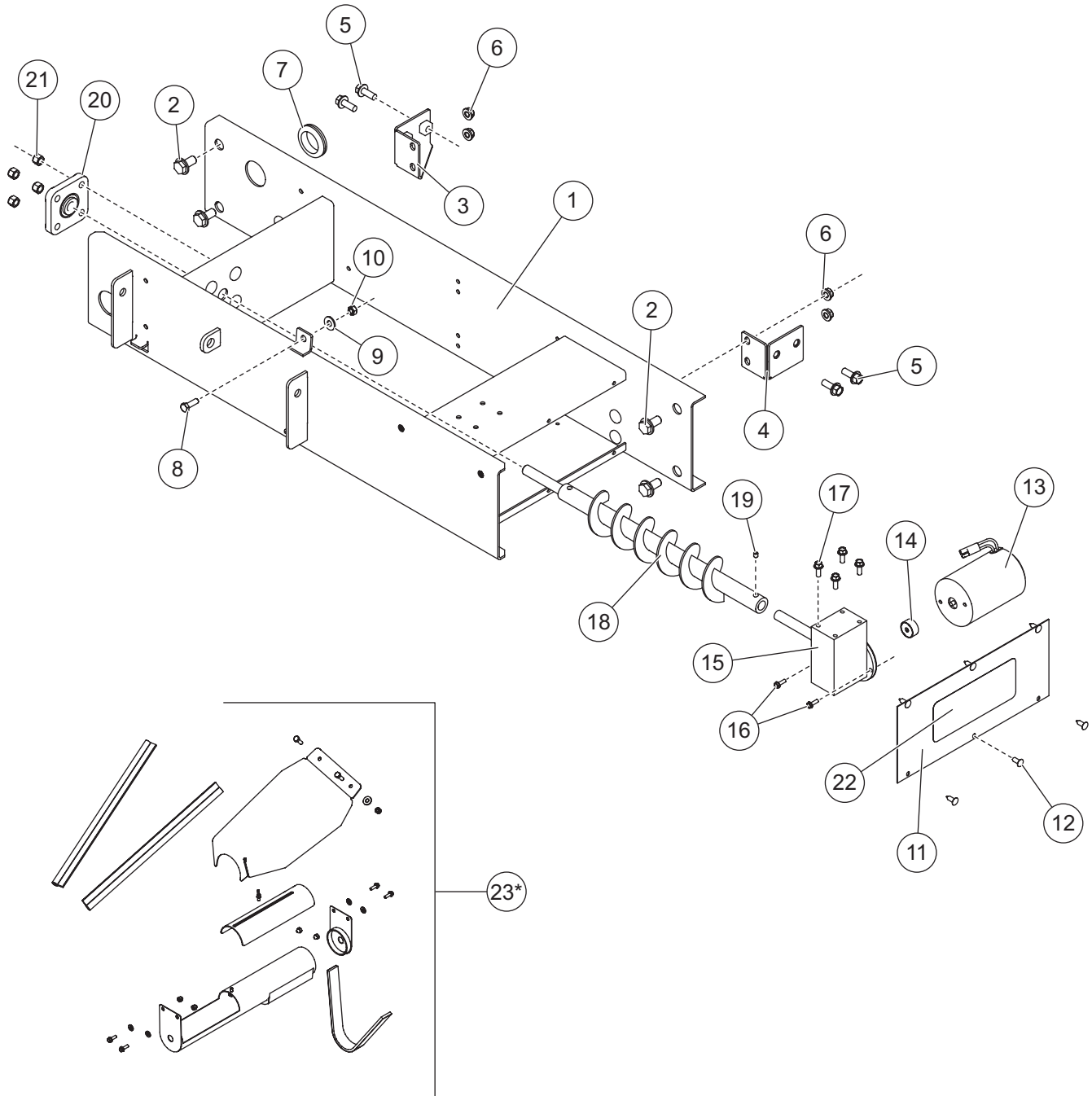

32300 & 32600 V-PRO™ HOPPER SPREADERS

Auger Assembly							
Item	Part	Qty	Description	Item	Part	Qty	Description
1	51076	1	Auger Drive Frame	13	51040	1	3" 12V DC Motor w/2-Pin Connector
2	51074	4	1/2-13 x 1 Serrated Flange Hex Cap Screw	14	51041	1	Motor Drive Coupler
3	51098	1	Lower Rail Mount Bracket, Left	15	51090	1	Transmission 30:1
4	88269	1	Lower Rail Mount Bracket, Right	16	51039	2	#10-32 x 5/8 Serrated Flange Hex Cap Screw w/Patch
5	51049	4	3/8-16 x 1 Serrated Flange Hex Cap Screw	17	51031	4	1/4-20 x 3/4 Serrated Flange Hex Cap Screw SS
6	51092	4	3/8-16 Serrated Flange Nut	18	51087	1	Auger
7	11066	1	Grommet – 1.5" ID, 2.125" OD	19	51034	1	5/16-18 x 3/8 Set Screw
8	68494	1	5/16-18 x 1 Hex Cap Screw G5	20	68662	1	5/8 Bearing 4-Bolt Flange
9	90313	1	5/16 Flat Washer	21	D4124	4	3/8-16 Locknut
10	91332	1	5/16-18 Hex Locknut GB	22	93114	1	Label – Warning, Rotating Auger
11	51077	1	Auger Motor Cover	23*	51107	–	Auger Tube Restrictor Kit
12	51050	6	1/4 x 3/4 x 1/2 Push Retainer				
		SS = Stainless Steel				G = Grade	
						ID = Inner Diameter	
						OD = Outer Diameter	

* = Accessory Only

32300 & 32600 V-PRO™ HOPPER SPREADERS

DRIVE ASSEMBLY

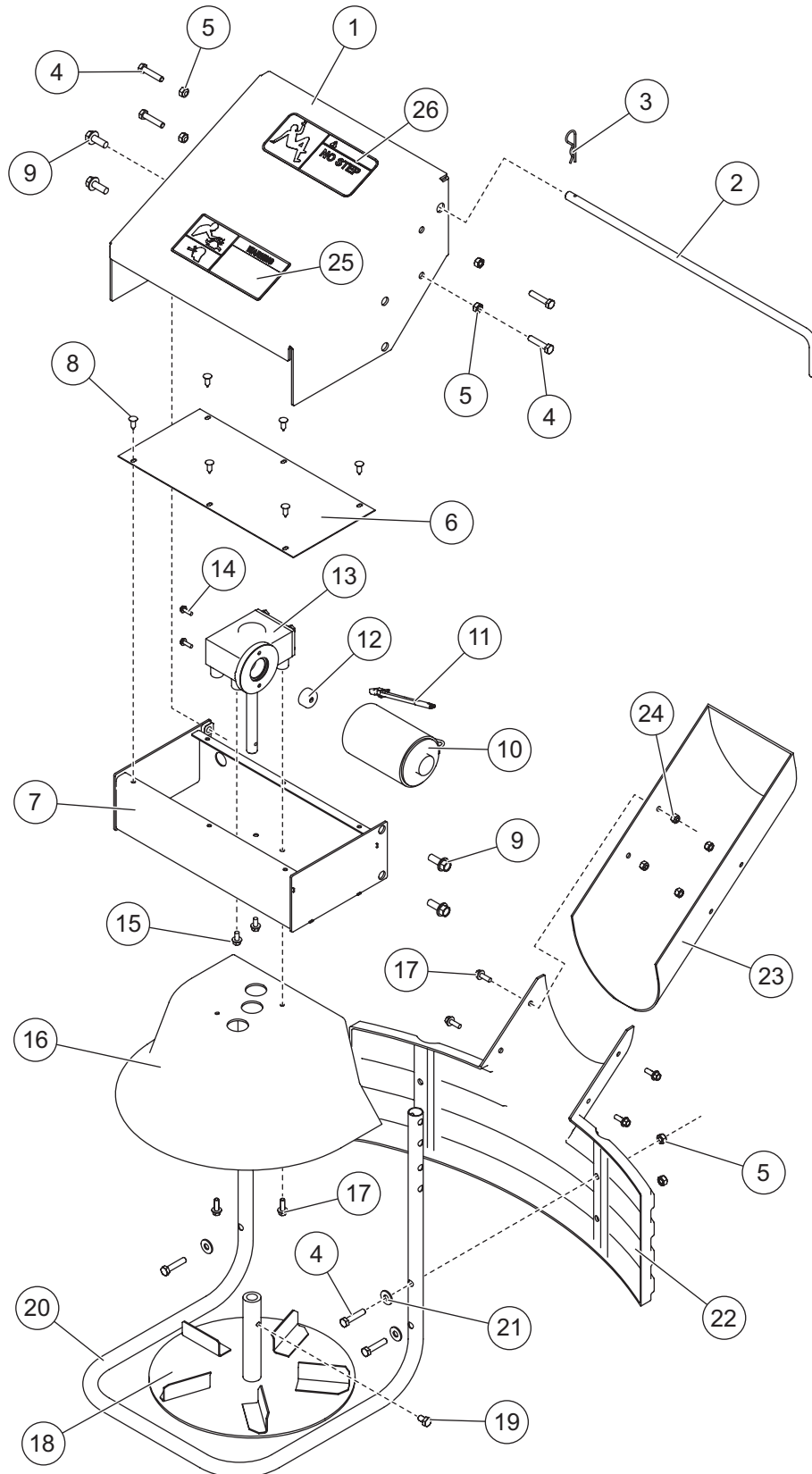

32300 & 32600 V-PRO™ HOPPER SPREADERS

32221 Drive Assembly							
Item	Part	Qty	Description	Item	Part	Qty	Description
1	51091	1	Drive Enclosure Shroud	15	51030	2	1/4-20 x 1/2 Serrated Flange Hex Cap Screw SS
2	51088	1	1/2 x 20 Bent Pin				
3	51024	1	0.093 x 2-3/8 Hairpin Cotter	16	51045	1	CE Shroud
4	51072	8	5/16-18 x 1-1/2 Tapping Screw	17	D6132	6	1/4-20 x 3/4 Serrated Flange Hex Cap Screw SS
5	91332	8	5/16-18 Hex Locknut GB				
6	51029	1	Spinner Drive Enclosure Cover	18	51069	1	Spinner w/Extended Shaft 12"
7	51080	1	Spinner Drive Enclosure	19	51032	1	5/16-18 x 1/2 Hex Cap Screw G5
8	51050	6	1/4 x 3/4 x 1/2 Push Retainer	20	51081	1	Tubular Spinner Guard
9	51049	4	3/8-16 x 1 Serrated Flange Hex Cap Screw Type F	21	90313	4	5/16 Flat Washer
10	51040	1	3" 12V DC Motor w/2-Pin	22	51089	1	Spinner Deflector
11	51097	1	Auger Motor Connector	23	51070	1	Material Chute
12	51041	1	Motor Drive Coupler	24	91331	4	1/4-20 Hex Locknut GB
13	51028	1	Transmission 8:1	25	93109	1	Label – Warning, Rotating Parts
14	51039	2	#10-32 x 5/8 Serrated Flange Hex Cap Screw w/Patch	26	93110	1	Label – Warning, No Step
SS = Stainless Steel				G = Grade			

32300 & 32600 V-PRO™ HOPPER SPREADERS

ELECTRICAL BOX ASSEMBLY

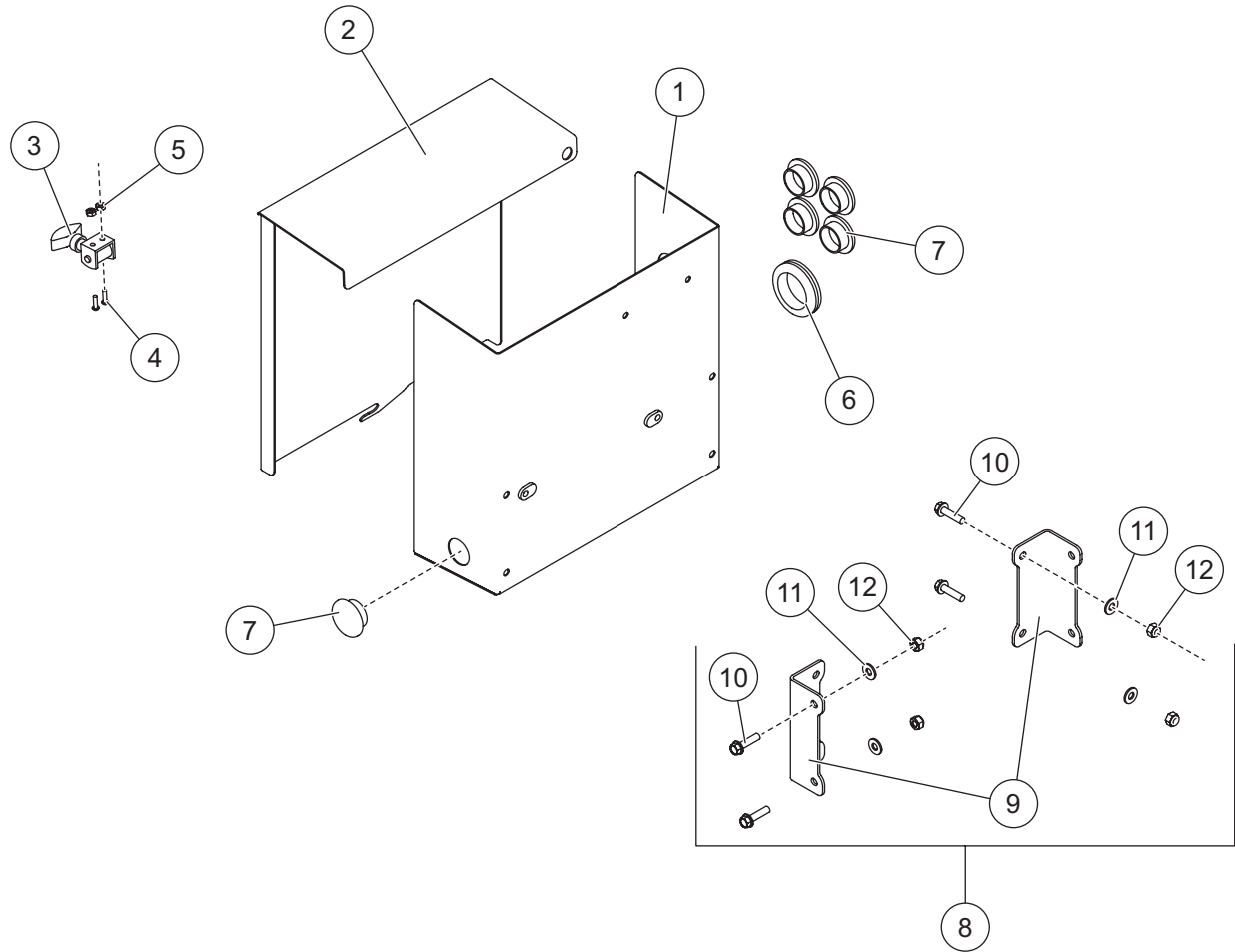

32300 & 32600 V-PRO™ HOPPER SPREADERS

ELECTRICAL COMPONENTS

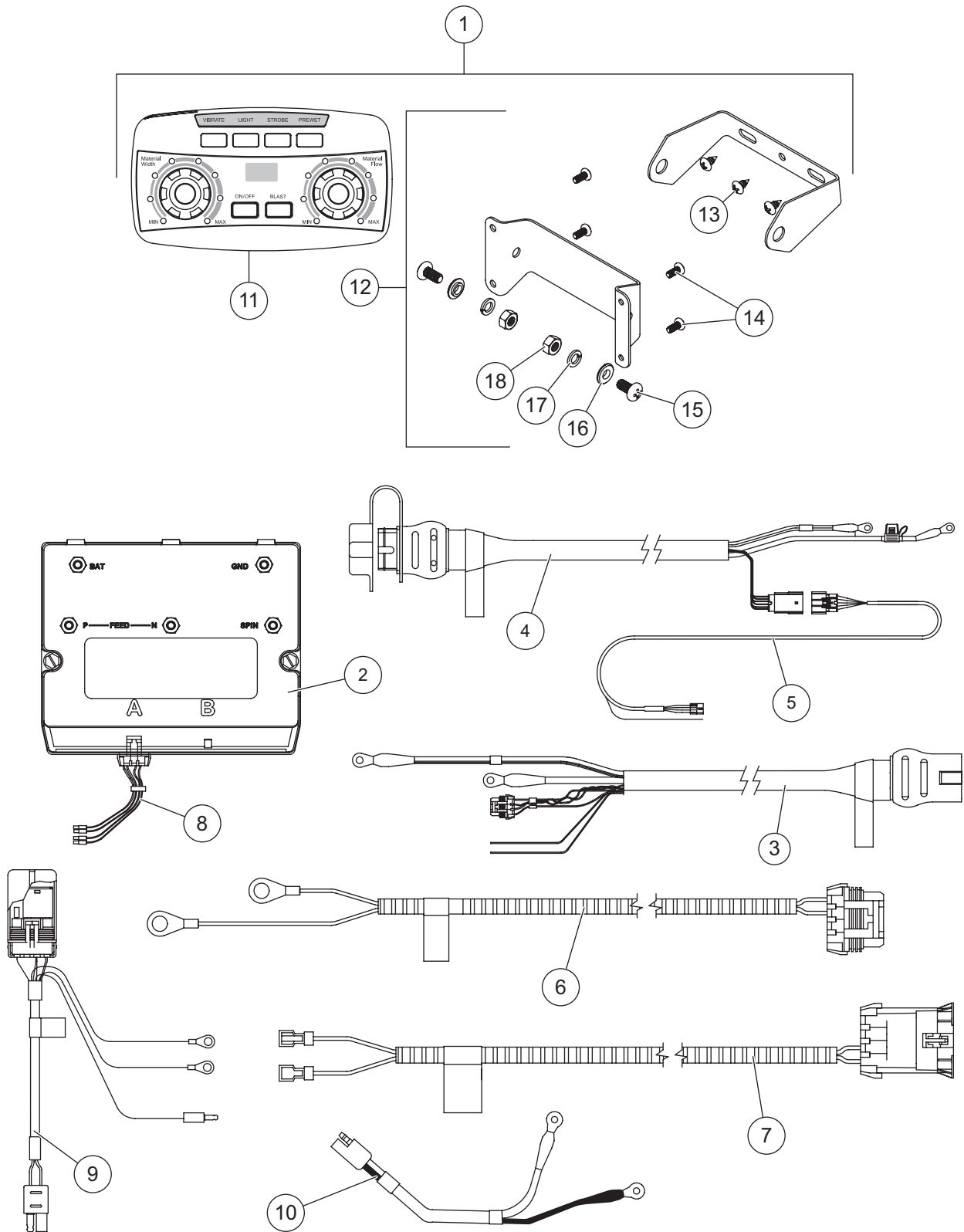

32300 & 32600 V-PRO™ HOPPER SPREADERS

Electrical Components							
Item	Part	Qty	Description	Item	Part	Qty	Description
1	52460	1	Spreader Control Kit	7	78359	1	Spinner Motor Cable Assembly w/ Blade Terminal
2	52375	1	Spreader Module, 5-Post	8	69893	1	10-Pin Connector w/Four Wires
3	72092	1	Spreader Harness, 7-Pin	9	78382	1	Vibrator Harness Assembly
4	72090	1	Vehicle Cable Assembly	10	78397	1	Auger Motor Harness
5	69902	1	Vehicle Control Harness				
6	78361	1	Spinner Motor Cable Assembly w/ Ring Terminals				
Item 1				52460 Spreader Control Kit			
11	52442	1	Spreader Control	12	52345	1	Control Bracket Kit
Item 12				52345 Control Bracket Kit			
13		3	#10 x 3/8 Pan Head Tapping Screw SS	16		2	1/4 Shoulder Washer SS
14		4	#8 x 3/8 Pan Head Machine Screw	17		2	1/4 Lock Washer SS
15		2	1/4-20 x 1/2 Pan Head Machine Screw SS	18		2	1/4-20 Hex Nut G5
SS = Stainless Steel				G = Grade			

32300 & 32600 V-PRO™ HOPPER SPREADERS



TrynEx International
531 Ajax Drive
Madison Heights, MI 48071-2429
www.snowexproducts.com

 A DIVISION OF DOUGLAS DYNAMICS, LLC

Copyright © 2019 Douglas Dynamics, LLC. All rights reserved. This material may not be reproduced or copied, in whole or in part, in any printed, mechanical, electronic, film, or other distribution and storage media, without the written consent of TrynEx International, LLC. Authorization to photocopy items for internal or personal use by TrynEx International outlets or spreader owner is granted.

TrynEx International reserves the right under its product improvement policy to change construction or design details and furnish equipment when so altered without reference to illustrations or specifications used. TrynEx International or the vehicle manufacturer may require or recommend optional equipment for spreaders. Do not exceed vehicle ratings with a spreader. TrynEx International offers a limited warranty for all spreaders and accessories. See separately printed page for this important information. The following are registered (®) or unregistered (™) trademarks of Douglas Dynamics, LLC: SnowEx®, V-Pro™.

Printed in U.S.A.